

Parker Pneumatic

Electronic Sensors
Solid State, Reed and Proximity Sensors

B
Electronic Sensors Actuator Products
Selection Guide
Drop-in Sensors
Solid State / Reed Sensors
Weld Immune Sensors
Cordset / Connect Block
NAMUR Sensors
Proximity Sensors



PNP Solid State Sensor Selection Guide

Series	Bore size or type	3M flying leads	10m flying leads	8mm quick connect*	8mm quick connect w/ 1 m lead*	12mm quick connect*	Bracket	Sensor page #	Bracket page #		
P1Q	12mm - 25mm	P8S-CPFLS	N/A	P8S-CPSHS	N/A	P8S-CPMHS	N/A	N/A	N/A		
	32mm - 100mm	P8S-CPFLR	N/A	P8S-CPSHR	N/A	P8S-CPMHR	N/A	N/A	N/A		
Compact cylinders	P1M standard sensor	All	P8S-GPFLX	P8S-GPFTX	P8S-GPSHX	P8S-GPSCX	P8S-GPMHX	N/A	B298	N/A	
	P1M right angle sensor	All	P8S-SPELXD	P8S-SPETXD	P8S-SPTHXD	N/A	N/A	N/A	B301	N/A	
	LPM	9/16"	L076990000 ²	N/A	L07699000C	N/A	N/A	N/A	N/A	B305	N/A
		3/4" - 1-1/8"	L077000000 ²	N/A	L07700000C	N/A	N/A	N/A	N/A	B305	N/A
1-1/2" - 2"		L077010000 ²	N/A	L07701000C	N/A	N/A	N/A	N/A	B305	N/A	
	2-1/2" - 4"	L077020000 ²	N/A	L07702000C	N/A	N/A	N/A	N/A	B305	N/A	
Round body cylinders	P1L	20 - 25mm	P8S-GPFLX	P8S-GPFTX	P8S-GPSHX	P8S-GPSCX	P8S-GPMHX	P8S-TMC01	B298	B301	
		32 - 63mm	P8S-GPFLX	P8S-GPFTX	P8S-GPSHX	P8S-GPSCX	P8S-GPMHX	P8S-TMC02	B298	B301	
		80 - 100mm	P8S-GPFLX	P8S-GPFTX	P8S-GPSHX	P8S-GPSCX	P8S-GPMHX	P8S-TMC03	B298	B301	
	SRM/SRDM	9/16" - 3/4"	P8S-GPFLX	P8S-GPFTX	P8S-GPSHX	P8S-GPSCX	P8S-GPMHX	P8S-TMC01	B298	B301	
		1-1/16" - 2-1/2"	P8S-GPFLX	P8S-GPFTX	P8S-GPSHX	P8S-GPSCX	P8S-GPMHX	P8S-TMC02	B298	B301	
	P	1-1/8" - 2-1/2"	P8S-GPFLX	P8S-GPFTX	P8S-GPSHX	P8S-GPSCX	P8S-GPMHX	P8S-TMC02	B298	B301	
		3" - 4"	P8S-GPFLX	P8S-GPFTX	P8S-GPSHX	P8S-GPSCX	P8S-GPMHX	P8S-TMC03	B298	B301	
Tie rod cylinders	3MA/4MA standard sensor	1-1/2" - 5"	P8S-GPFLX	P8S-GPFTX	P8S-GPSHX	P8S-GPSCX	P8S-GPMHX	N/A	B298	N/A	
	3MA/4MA	6" - 8"						P8S-TMA0X	B298	N/A	
	3MA/4MA mini global sensor	1-1/8" - 5"	P8S-MPFLX	P8S-MPFTX	P8S-MPSHX	N/A	N/A	P8S-TMA0Z	B300	N/A	
Iso cylinders	P1A standard sensor	10-25mm	P8S-GPFLX	P8S-GPFTX	P8S-GPSHX	P8S-GPSCX	P8S-GPMHX	P8S-TMC01	B298	B301	
	P1A right angle sensors	10mm	P1A-2XMK ¹	N/A	N/A	N/A	N/A	P1A-2CCC	B304	B304	
		12mm	P1A-2XMK ¹	N/A	N/A	N/A	N/A	P1A-2DCC	B304	B304	
		16mm	P1A-2XMK ¹	N/A	N/A	N/A	N/A	P1A-2FCC	B304	B304	
		20mm	P1A-2XMK ¹	N/A	N/A	N/A	N/A	P1A-2HCC	B304	B304	
		25mm	P1A-2XMK ¹	N/A	N/A	N/A	N/A	P1A-2JCC	B304	B304	
	P1D standard & clean profiles	All	P8S-GPFLX	P8S-GPFTX	P8S-GPSHX	P8S-GPSCX	P8S-GPMHX	N/A	B298	N/A	
P1D standard profile mini sensors	All	P8S-MPFLX	P8S-MPFTX	P8S-MPSHX	N/A	N/A	N/A	B300	N/A		
P1D tie rod version	All	P8S-GPFLX	P8S-GPFTX	P8S-GPSHX	P8S-GPSCX	P8S-GPMHX	P8S-TMA0X	B298	N/A		
Rodless cylinders	P1X	All	P8S-GPFLX	P8S-GPFTX	P8S-GPSHX	P8S-GPSCX	P8S-GPMHX	P8S-TMA0Y	B298	N/A	
	P1Z	All	P8S-GPFLX	P8S-GPFTX	P8S-GPSHX	P8S-GPSCX	P8S-GPMHX	N/A	B298	N/A	
	OSP-P	All	KL3308 ¹	KL3309 ⁴	KL3312	N/A	N/A	N/A	B303	N/A	
Guided cylinders	P5T	Flush mount	P8S-GPFLX	P8S-GPFTX	P8S-GPSHX	P8S-GPSCX	P8S-GPMHX	N/A	B298	N/A	
		Right angle	P8S-SPELXD	P8S-SPETXD	P8S-SPTHXD	N/A	N/A	Included w/ sensor	B299	N/A	
	P5T2	All	P8S-GPFLX	P8S-GPFTX	P8S-GPSHX	P8S-GPSCX	P8S-GPMHX	N/A	B298	N/A	
	P5E	All	P8S-GPFLX	P8S-GPFTX	P8S-GPSHX	P8S-GPSCX	P8S-GPMHX	N/A	B298	N/A	
	HB	All	P8S-GPFLX	P8S-GPFTX	P8S-GPSHX	P8S-GPSCX	P8S-GPMHX	N/A	B298	N/A	
		20 - 25mm	P8S-GPFLX	P8S-GPFTX	P8S-GPSHX	P8S-GPSCX	P8S-GPMHX	P8S-TMC01	B298	B301	
32 - 63mm		P8S-GPFLX	P8S-GPFTX	P8S-GPSHX	P8S-GPSCX	P8S-GPMHX	P8S-TMC02	B298	B301		
P5L	80 - 100mm	P8S-GPFLX	P8S-GPFTX	P8S-GPSHX	P8S-GPSCX	P8S-GPMHX	P8S-TMC03	B298	B301		
Rotary actuators	PV WR XR	Normally open	SMH-1P ²	N/A	SMH-1PC	N/A	N/A	N/A	B307	N/A	
		Normally closed	SMC-1P ²	N/A	SMC-1PC	N/A	N/A	N/A	B307	N/A	
	PRN(A)	All	N/A	N/A	N/A	N/A	N/A	N/A	N/A	N/A	
	PTR	10, 15	SWH-1P ³	N/A	SWH-1PC	N/A	N/A	Included	B308	N/A	
20, 25, 32		SWH-2P ³	N/A	SWH-2PC	N/A	N/A	Included	B308	N/A		

1. Flying leads are 2 meters in length
 2. Flying Leads are 1.5 meters in length

3. Flying leads are 1 meter in length
 4. Flying leads are 5 meter in length

Note: See page B309 for Weld Immune Sensors and pages B311-B313 for NAMUR Intrinsically Safe Sensors.
 * See page B317 for cord sets.

B
 Electronic Sensors
 Actuator Products
 Selection Guide
 Drop-in Sensors
 Solid State / Reed Sensors
 Weld Immune Sensors
 Cordset / Connect Block
 NAMUR Sensors
 Proximity Sensors



NPN Solid State Sensor Selection Guide

Series	Bore size or type	3m flying leads	10m flying leads	8mm quick connect*	8mm quick connect w/ 1m lead*	12mm quick connect*	Bracket	Sensor page #	Bracket page #		
P1Q	12mm - 25mm	P8S-CNFLS	N/A	P8S-CNSHS	N/A	P8S-CNMHS	N/A	N/A	N/A		
	32mm - 100mm	P8S-CNFLR	N/A	P8S-CNSHR	N/A	P8S-CNMHR	N/A	N/A	N/A		
Compact cylinders	P1M standard sensor	All	P8S-GNFLX	P8S-GNFTX	P8S-GNSHX	P8S-GNSCX	P8S-GNMHX	N/A	B298	N/A	
	P1M right angle sensor	All	P8S-SNELX	P8S-SNETX	P8S-SNTHX	N/A	N/A	N/A	B301	N/A	
	LPM	9/16"	L076950000 ²	N/A	L07695000C	N/A	N/A	N/A	N/A	B305	N/A
		3/4" - 1-1/8"	L076960000 ²	N/A	L07696000C	N/A	N/A	N/A	N/A	B305	N/A
1-1/2" - 2"		L076970000 ²	N/A	L07697000C	N/A	N/A	N/A	N/A	B305	N/A	
	2-1/2" - 4"	L076980000 ²	N/A	L07698000C	N/A	N/A	N/A	N/A	B305	N/A	
Round body cylinders	P1L	20 - 25mm	P8S-GNFLX	P8S-GNFTX	P8S-GNSHX	P8S-GNSCX	P8S-GNMHX	P8S-TMC01	B298	B301	
		32 - 63mm	P8S-GNFLX	P8S-GNFTX	P8S-GNSHX	P8S-GNSCX	P8S-GNMHX	P8S-TMC02	B298	B301	
		80 - 100mm	P8S-GNFLX	P8S-GNFTX	P8S-GNSHX	P8S-GNSCX	P8S-GNMHX	P8S-TMC03	B298	B301	
	SRM/SRDM	9/16" - 3/4"	P8S-GNFLX	P8S-GNFTX	P8S-GNSHX	P8S-GNSCX	P8S-GNMHX	P8S-TMC01	B298	B301	
		1-1/16" - 2-1/2"	P8S-GNFLX	P8S-GNFTX	P8S-GNSHX	P8S-GNSCX	P8S-GNMHX	P8S-TMC02	B298	B301	
	P	1-1/8" - 2-1/2"	P8S-GNFLX	P8S-GNFTX	P8S-GNSHX	P8S-GNSCX	P8S-GNMHX	P8S-TMC02	B298	B301	
	3" - 4"	P8S-GNFLX	P8S-GNFTX	P8S-GNSHX	P8S-GNSCX	P8S-GNMHX	P8S-TMC03	B298	B301		
Tie rod cylinders	3MA/4MA standard sensor	1-1/2" - 5"	P8S-GNFLX	P8S-GPNFTX	P8S-GNSHX	P8S-GPNSCX	P8S-GNMHX	N/A	B298	N/A	
	3MA/4MA	6" - 8"					P8S-TMA0X	B298	N/A		
	3MA/4MA mini-global sensor	1-1/8" - 5"	P8S-MNFLX	P8S-MNFTX	P8S-MNSHX	N/A	N/A	P8S-TMA0Z	B300	N/A	
ISO cylinders	P1A standard sensor	10-25mm	P8S-GNFLX	P8S-GNFTX	P8S-GNSHX	P8S-GNSCX	P8S-GNMHX	P8S-TMC01	B298	B301	
		10mm bore	P1A-2XLK ¹	N/A	N/A	N/A	N/A	P1A-2CCC	B304	B304	
	P1A right angle sensors	12mm bore	P1A-2XLK ¹	N/A	N/A	N/A	N/A	P1A-2DCC	B304	B304	
		16mm bore	P1A-2XLK ¹	N/A	N/A	N/A	N/A	P1A-2FCC	B304	B304	
		20mm bore	P1A-2XLK ¹	N/A	N/A	N/A	N/A	P1A-2HCC	B304	B304	
	25mm bore	P1A-2XLK ¹	N/A	N/A	N/A	N/A	P1A-2JCC	B304	B304		
Solid State / Reed Sensors	P1D standard & clean profiles	All	P8S-GNFLX	P8S-GNFTX	P8S-GNSHX	P8S-GNSCX	P8S-GNMHX	N/A	B298	N/A	
	P1D standard profile mini Sensors	All	P8S-MNFLX	P8S-MNFTX	P8S-MNSHX	N/A	N/A	N/A	B300	N/A	
	P1D tie rod version	All	P8S-GNFLX	P8S-GNFTX	P8S-GNSHX	P8S-GNSCX	P8S-GNMHX	P8S-TMA0X	B298	N/A	
Rodless Cylinders	P1X	All	P8S-GNFLX	P8S-GNFTX	P8S-GNSHX	P8S-GNSCX	P8S-GNMHX	P8S-TMA0Y	B298	N/A	
	P1Z	All	P8S-GNFLX	P8S-GNFTX	P8S-GNSHX	P8S-GNSCX	P8S-GNMHX	N/A	B298	N/A	
	OSP-P	All	N/A	N/A	N/A	N/A	N/A	N/A	N/A	N/A	
Weld Immune Sensors	P5T	Flush mount	P8S-GNFLX	P8S-GNFTX	P8S-GNSHX	P8S-GNSCX	P8S-GNMHX	N/A	B298	N/A	
		Right angle	P8S-SNELX	P8S-SNETX	P8S-SNTHX	N/A	N/A	N/A	B299	N/A	
	P5T2	All	P8S-GNFLX	P8S-GNFTX	P8S-GNSHX	P8S-GNSCX	P8S-GNMHX	N/A	B298	N/A	
	P5E	All	P8S-GNFLX	P8S-GNFTX	P8S-GNSHX	P8S-GNSCX	P8S-GNMHX	N/A	B298	N/A	
	HB	All	P8S-GNFLX	P8S-GNFTX	P8S-GNSHX	P8S-GNSCX	P8S-GNMHX	N/A	B298	N/A	
Cordset / Connect Block	P5L	20 - 25mm	P8S-GNFLX	P8S-GNFTX	P8S-GNSHX	P8S-GNSCX	P8S-GNMHX	P8S-TMC01	B298	B301	
		32 - 63mm	P8S-GNFLX	P8S-GNFTX	P8S-GNSHX	P8S-GNSCX	P8S-GNMHX	P8S-TMC02	B298	B301	
		80 - 100mm	P8S-GNFLX	P8S-GNFTX	P8S-GNSHX	P8S-GNSCX	P8S-GNMHX	P8S-TMC03	B298	B301	
Rotary actuators	PV WR XR	Normally open	SMH-1N ²	N/A	SMC-1NC	N/A	N/A	N/A	B307	N/A	
		Normally closed	SMC-1N ²	N/A	SMC-1NC	N/A	N/A	N/A	B307	N/A	
	PRN(A)	All	See page B306								
	PTR	10, 15	SWH-1N ³	N/A	SWH-1NC	N/A	N/A	Included	B308	N/A	
20, 25, 32		SWH-2N ³	N/A	SWH-2NC	N/A	N/A	Included	B308	N/A		

1 Flying leads are 2 meters in length
 2 Flying Leads are 1.5 meters in length
 3 Flying leads are 1 meter in length

Note: See page B309 for Weld Immune Sensors and pages B311-B313 for NAMUR Intrinsically Safe Sensors.
 * See page B317 for cord sets.



B
 Electronic Sensors
 Actuator Products
 Selection Guide
 Drop-in Sensors
 Solid State / Reed Sensors
 Weld Immune Sensors
 Cordset / Connect Block
 NAMUR Sensors
 Proximity Sensors

Reed Sensor Selection Guide

Series	Bore size or type	3m flying leads	10m flying leads	8mm quick connect*	8 mm quick connect w/ 1 m lead*	12mm quick connect*	Bracket	Sensor page #	Bracket page #		
P1Q	12mm - 25mm	P8S-CRFLS	N/A	P8S-CRSHS	N/A	P8S-CRMHS	N/A	N/A	N/A		
	32mm - 100mm	P8S-CRFLR	N/A	P8S-CRSHR	N/A	P8S-CRMRH	N/A	N/A	N/A		
Compact cylinders	P1M standard sensor	All	P8S-GRFLX	P8S-GRFTX	P8S-GRSHX	P8S-GRSCX	P8S-GRMHX	N/A	B299	N/A	
	P1M right angle sensor	All	P8S-SRELX	P8S-SRETX	P8S-SRTHX	N/A	N/A	N/A	B301	N/A	
	LPM	9/16"	L077030000 ¹	N/A	L07703000C	N/A	N/A	N/A	N/A	B305	N/A
		3/4" - 1-1/8"	L077040000 ¹	N/A	L07704000C	N/A	N/A	N/A	N/A	B305	N/A
1-1/2" - 2"		L077050000 ¹	N/A	L07705000C	N/A	N/A	N/A	N/A	B305	N/A	
	2-1/2" - 4"	L077060000 ¹	N/A	L07706000C	N/A	N/A	N/A	N/A	B305	N/A	
Round body cylinders	P1L	20 - 25mm	P8S-GRFLX	P8S-GRFTX	P8S-GRSHX	P8S-GRSCX	P8S-GRMHX	P8S-TMC01	B299	B301	
		32 - 63mm	P8S-GRFLX	P8S-GRFTX	P8S-GRSHX	P8S-GRSCX	P8S-GRMHX	P8S-TMC02	B299	B301	
		80 - 100mm	P8S-GRFLX	P8S-GRFTX	P8S-GRSHX	P8S-GRSCX	P8S-GRMHX	P8S-TMC03	B299	B301	
	SRM/SRDM	9/16" - 3/4"	P8S-GRFLX	P8S-GRFTX	P8S-GRSHX	P8S-GRSCX	P8S-GRMHX	P8S-TMC01	B299	B301	
		1-1/16" - 2-1/2"	P8S-GRFLX	P8S-GRFTX	P8S-GRSHX	P8S-GRSCX	P8S-GRMHX	P8S-TMC02	B299	B301	
	P	1-1/8" - 2-1/2"	P8S-GRFLX	P8S-GRFTX	P8S-GRSHX	P8S-GRSCX	P8S-GRMHX	P8S-TMC02	B299	B301	
		3" - 4"	P8S-GRFLX	P8S-GRFTX	P8S-GRSHX	P8S-GRSCX	P8S-GRMHX	P8S-TMC03	B299	B301	
Tie rod cylinders	3MA/4MA standard sensor	1-1/2" - 5"	P8S-GRFLX	P8S-GRFTX	P8S-GRSHX	P8S-GRSCX	P8S-GRMHX	N/A	B299	N/A	
	3MA/4MA	6" - 8"						P8S-TMA0X	B299	N/A	
	3MA/4MA mini global sensor	1-1/8" - 5"	P8S-MRFLX	P8S-MRFTX	P8S-MRSHX	N/A	N/A	P8S-TMA0Z	B299	N/A	
ISO cylinders	P1A standard sensor	10-25mm	P8S-GRFLX	P8S-GRFTX	P8S-GRSHX	P8S-GRSCX	P8S-GRMHX	P8S-TMC01	B299	B301	
	P1A alternate sensors	10mm bore	P1A-2XRL	N/A	P1A-2XSH	N/A	N/A	P1A-2CCB	B304	B304	
		12mm bore	P1A-2XRL	N/A	P1A-2XSH	N/A	N/A	P1A-2DCB	B304	B304	
		16mm bore	P1A-2XRL	N/A	P1A-2XSH	N/A	N/A	P1A-2FCB	B304	B304	
		20mm bore	P1A-2XRL	N/A	P1A-2XSH	N/A	N/A	P1A-2HCB	B304	B304	
		25mm bore	P1A-2XRL	N/A	P1A-2XSH	N/A	N/A	P1A-2JCB	B304	B304	
P1D standard & clean profiles	All	P8S-GRFLX	P8S-GRFTX	P8S-GRSHX	P8S-GRSCX	P8S-GRMHX	N/A	B299	N/A		
P1D standard profile mini sensors	All	P8S-MRFLX	P8S-MRFTX	P8S-MRSHX	N/A	N/A	N/A	B300	N/A		
P1D tie rod version	All	P8S-GRFLX	P8S-GRFTX	P8S-GRSHX	P8S-GRSCX	P8S-GRMHX	P8S-TMA0X	B299	N/A		
Rodless cylinders	P1X	All	P8S-GRFLX	P8S-GRFTX	P8S-GRSHX	P8S-GRSCX	P8S-GRMHX	P8S-TMA0Y	B299	N/A	
	P1Z	All	P8S-GRFLX	P8S-GRFTX	P8S-GRSHX	P8S-GRSCX	P8S-GRMHX	N/A	B299	N/A	
	OSP-P	All	KL3301 ³	KL3300 ⁴	KL3302	N/A	N/A	Included w/ sensor	B303	N/A	
Guided cylinders	P5T	Flush mount	P8S-GRFLX	P8S-GRFTX	P8S-GRSHX	P8S-GRSCX	P8S-GRMHX	N/A	B299	N/A	
		Right angle	P8S-SRELX	P8S-SRETX	P8S-SRTHX	N/A	N/A	N/A	B299	N/A	
	P5T2	All	P8S-GRFLX	P8S-GRFTX	P8S-GRSHX	P8S-GRSCX	P8S-GRMHX	N/A	B299	N/A	
	P5E	All	P8S-GRFLX	P8S-GRFTX	P8S-GRSHX	P8S-GRSCX	P8S-GRMHX	N/A	B299	N/A	
	HB	All	P8S-GRFLX	P8S-GRFTX	P8S-GRSHX	P8S-GRSCX	P8S-GRMHX	N/A	B299	N/A	
P5L		20 - 25mm	P8S-GRFLX	P8S-GRFTX	P8S-GRSHX	P8S-GRSCX	P8S-GRMHX	P8S-TMC01	B299	B299	
		32 - 63mm	P8S-GRFLX	P8S-GRFTX	P8S-GRSHX	P8S-GRSCX	P8S-GRMHX	P8S-TMC02	B299	B299	
	80 - 100mm	P8S-GRFLX	P8S-GRFTX	P8S-GRSHX	P8S-GRSCX	P8S-GRMHX	P8S-TMC03	B299	B299		
Rotary actuators	PV WR XR	N.O. high amp	SMR-1 ¹	N/A	SMR-1C	N/A	N/A	N/A	B307	N/A	
		N.O. low amp	SMR-1L ¹	N/A	SMR-1LC	N/A	N/A	N/A	B307	N/A	
		N.C.	SMD-1L ¹	N/A	SMD-1LC	N/A	N/A	N/A	B307	N/A	
PRN	50 - 800	See model code						B306	N/A		
PTR	10, 15	SWR-1 ²	N/A	SWR-1C	N/A	N/A	Included	B308	N/A		
	20, 25, 32	SWR-2 ²	N/A	SWR-2C	N/A	N/A	Included	B308	N/A		

1. Flying leads are 1.5 meters in length
 2. Flying Leads are 1 meters in length

3. Flying leads are 2 meter in length
 4. Flying leads are 5 meter in length

Note: See page B309 for Weld Immune Sensors and pages B311-B313 for NAMUR Intrinsically Safe Sensors.
 * See page B317 for cord sets.



P8S Global Drop-In Solid State Sensors



Wiring	PNP sensor	NPN sensor	PNP sensor ATEX certified
3m flying leads	P8S-GPFLX	P8S-GNFLX	P8S-GPFLX/EX
10m flying leads	P8S-GPFTX	P8S-GNFTX	
0.3m lead with 8mm connector	P8S-GPSHX	P8S-GNSHX	N/A
0.3m lead with 12mm connector	P8S-GPMHX	P8S-GNMHX	
1m lead with 8mm connector	P8S-GPSCX	P8S-GNSCX	

B
 Electronic Sensors
 Actuator Products
 Selection Guide
 Drop-in Sensors
 Solid State / Reed Sensors
 Weld Immune Sensors
 Cordset / Connect Block
 NAMUR Sensors
 Proximity Sensors

Wiring connection

Flying lead or 8 mm connector (shown)

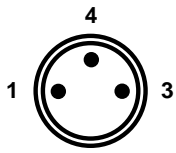

Pin	Wire	Function
1	Brown	Operating voltage (+VDC)
4	Black	Output signal (N.O.)
3	Blue	-VDC

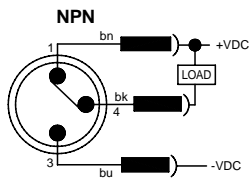
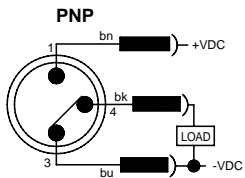

12 mm connector

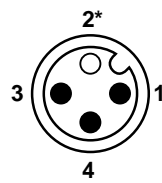

Pin	Wire	Function
1	Brown	Operating voltage (+VDC)
4	Black	Output signal (N.O.)
2*	White	Not used
3	Blue	-VDC

* Pin 2 not present.

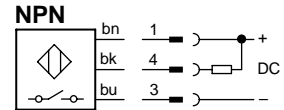
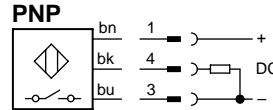

P8S Global Drop-in Reed Sensors



Wiring	Reed sensor
3m flying leads	P8S-GRFLX
10m flying leads	P8S-GRFTX
0.3m lead with 8mm connector	P8S-GRSHX
0.3m lead with 12mm connector	P8S-GRMHX
1m lead with 8mm connector	P8S-GRSCX

Circuit for switching contact protection (for inductive loads, e.g. solenoids, relays)

(Required for proper operation 24VDC)

Put diode parallel to load (CR) following polarity as shown below.

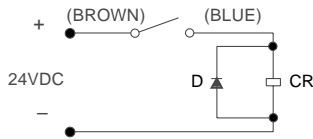

D: Diode: select a diode with the breakdown voltage and current rating according to the load.

Typical Example – 100 volt, 1 amp diode
 CR: Relay coil (under 0.5W coil rating)

(Recommended for longer life 120 VAC)

Put a resistor and capacitor in parallel with the load (CR). Select the resistor and capacitor according to the load.

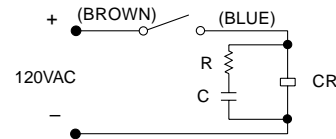

Typical Example:

CR: Relay coil (under 2W coil rating)
 R: Resistor 1 K Ω - 5 K Ω , 1/4 W
 C: Capacitor 0.1 Ω F, 600 V

⚠ Caution

- Use an ampmeter to test reed sensor current. Testing devices such as incandescent light bulbs may subject the reed sensor to high in-rush loads.
- **NOTE:** When checking an unpowered reed sensor for continuity with a digital ohmmeter the resistance reading will change from infinity to a very large resistance (2 M ohm) when the sensor is activated. This is due to the presence of a diode in the reed sensor.
- Anti-magnetic shielding is recommended for reed sensors exposed to high external RF or magnetic fields.
- The magnetic field strength of the piston magnet is designed to operate with our sensors. Other manufacturers' sensors may not operate correctly in conjunction with these magnets.

- Use relay coils for reed sensor contact protection.
- The operation of some 120 VAC PLC's (especially some older Allen-Bradley PLC's) can overload the reed sensor. The sensor may fail to release after the piston magnet has passed. This problem may be corrected by the placement of a 700 to 1K OHM resistor between the sensor and the PLC input terminal. Consult the manufacturer of the PLC for appropriate circuit.
- Sensors with long wire leads (greater than 15 feet) can cause capacitance build-up and sticking will result. Attach a resistor in series with the reed sensor (the resistor should be installed as close as possible to the sensor). The resistor should be selected such that $R \text{ (ohms)} > E/0.3$.

P8S Mini-Global Drop-In Solid State Sensors



Wiring	PNP sensor	NPN sensor
3m flying leads	P8S-MPFLX	P8S-MNFLX
10m flying leads	P8S-MPFTX	P8S-MNFTX
0.3m lead with 8mm connector	P8S-MPSHX	P8S-MNSHX

Wiring connection

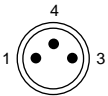

Pin	Wire	Function
1	Brown	+VDC
4	Black	NO
3	Blue	- VDC

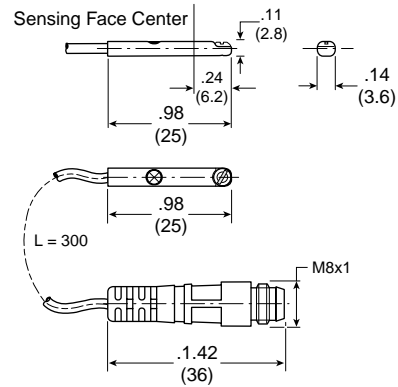
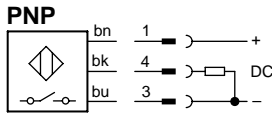
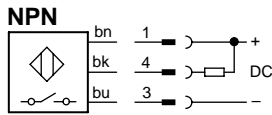

B
 Electronic Sensors
 Actuator Products
 Selection Guide
 Drop-in Sensors
 Solid State / Reed Sensors
 Weld Immune Sensors
 Cordset / Connect Block
 NAMUR Sensors
 Proximity Sensors

P8S Mini-Global Drop-In Reed Sensors



Wiring	Reed sensor
3m flying leads	P8S-MRFLX
10m flying leads	P8S-MRFTX
0.3m lead with 8mm connector	P8S-MRSHX

Wiring connection

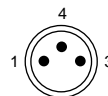

Pin	Wire	Function
1	Brown	Operating voltage (+V)
4	Black	Output signal
3	Blue	Ground (-V)

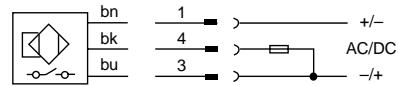

Caution

- Use an ammeter to test reed sensor current. Testing devices such as incandescent light bulbs may subject the reed sensor to high in-rush loads.
- **NOTE:** When checking an unpowered reed sensor for continuity with a digital ohmmeter the resistance reading will change from infinity to a very large resistance (2 M ohm) when the sensor is activated. This is due to the presence of a diode in the reed sensor.
- Anti-magnetic shielding is recommended for reed sensors exposed to high external RF or magnetic fields.
- The magnetic field strength of the piston magnet is designed to operate with our sensors. Other manufacturers' sensors may not operate correctly in conjunction with these magnets.

- Use relay coils for reed sensor contact protection.
- The operation of some 120 VAC PLC's (especially some older Allen-Bradley PLC's) can overload the reed sensor. The sensor may fail to release after the piston magnet has passed. This problem may be corrected by the placement of a 700 to 1K OHM resistor between the sensor and the PLC input terminal. Consult the manufacturer of the PLC for appropriate circuit.
- Sensors with long wire leads (greater than 15 feet) can cause capacitance build-up and sticking will result. Attach a resistor in series with the reed sensor (the resistor should be installed as close as possible to the sensor). The resistor should be selected such that $R \text{ (ohms)} > E/0.3$.



Tie Rod Bracket Assembly Part Number and Dimensions

Tie Rod Bracket Assembly is necessary for Global and Mini-Global Sensor installation on all tie rod construction cylinders. This includes all Intermediate Trunnion mounts (Style DD or MT4); some 1-1/8" bore 3MA Series mounts; and all 6"-8" bore Sensors and bracket assemblies must be ordered separately.

Part number P8S-TMA0X fits 1-1/2" to 8" bores and 32-200mm bores for Global Sensors
 Part number P8S-TMA0Z fits 1-1/8" bore for Mini-Global Sensors

P8S-TMA0X

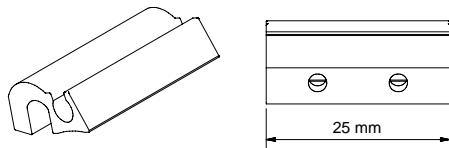
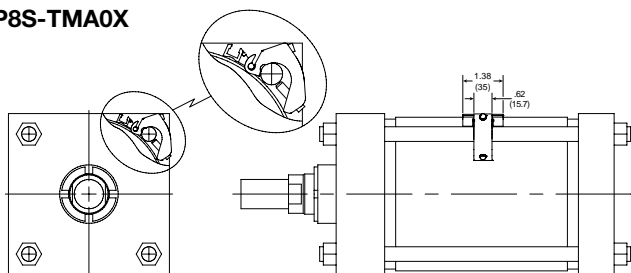

P8S-TMA0Z

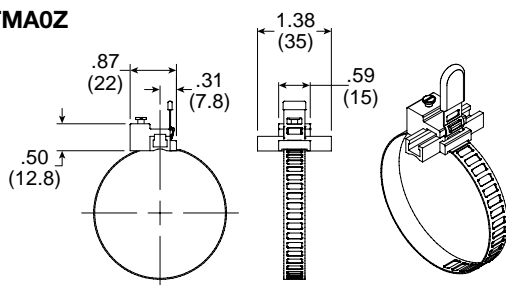

Round body bracket assembly part numbers Sensors and brackets must be ordered separately

Bore size	Round body bracket
9/16" - 1-1/16"	P8S-TMC01
20 - 25mm	P8S-TMC01
1-1/8" - 2-1/2"	P8S-TMC02
32 - 63mm	P8S-TMC02
3" - 4"	P8S-TMC03
80 - 100mm	P8S-TMC03

P8S Right Angle Solid State Sensors



Wiring	PNP sensors	NPN sensors
0.2m lead with 8mm connector	P8S-SPTHXD	P8S-SNTHX
3m flying leads	P8S-SPELXD	P8S-SNELX
10m flying leads	P8S-SPETXD	P8S-SNETX

Wiring connection

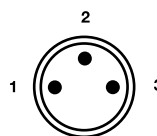

Pin	Wire	Function
1	Brown	Operating voltage (+VDC)
2	Black	Output signal (N.O.)
3	Blue	-VDC

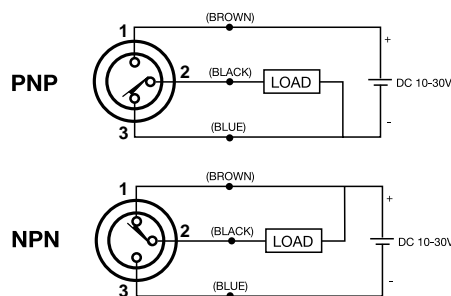

P8S Right Angle Reed Sensors



Wiring	Reed sensors
0.2m lead with 8mm connector	P8S-SRTHX
3m flying leads	P8S-SRELX
10m flying leads	P8S-SRETX

Wiring connection

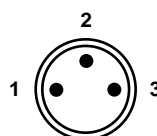

Pin	Wire	Function
1	Brown	Operating voltage (+V)
3	Black	Not used
2	Blue	Output signal (-V or Ground)

B

Electronic Sensors
 Actuator Products

Selection
 Guide

Drop-in
 Sensors

Solid State /
 Reed Sensors

Weld Immune
 Sensors

Cordset/
 Connect Block

NAMUR
 Sensors

Proximity
 Sensors

OSP-P Magnetic Switches for T-Slot – Series RST & EST

Magnetic switches are used for electrical sensing of the position of the piston, e.g. at its end positions. They can also be used for sensing of intermediate positions.

Sensing is contactless, based on magnets which are built-in as standard. A yellow LED indicates operating status.

The universal magnetic switches are suitable for all OSP-P Actuators.

1) For the magnetic switch temperature range, please take into account the surface temperature and the self-heating properties of the linear drive.



Characteristics

Electrical characteristics	Unit	Type RST	Type EST
Switching output		Reed	PNP
Operating voltage	V	10-30 AC/DC	10-30 DC
Ripple		–	≤ 10%
Voltage drop	V	≤ 3	≤ 2
Electrical configuration		Two wire	Three wire
Output function		normally open normally closed	normally open
Permanent current	mA	≤ 100	≤ 100
Breaking capacity	W	≤ 6 peak	–
Power consumption at UB = 24V, switched on, without load	mA	–	≤ 10
Function indicator		LED, yellow (not for normally closed)	
Response time	ms	≤ 2	≤ 0.5
Sensitivity	mT	2 – 4	2 – 4
Time delay before availability	ms	–	≤ 2
Reverse polarity protection		Yes	Yes
Short-circuit protection		No	Yes (pulsed)
Switchable capacity load	µF	0.1 at 100 W, 24 VDC	
Switching frequency	Hz	≤ 400	≤ 5k
Repeatability	mm	≤ 0.2	≤ 0.2
Hysteresis	mm	≤ 1.5	≤ 1.5
EMC	EN	60947-5-2	
Lifetime		≥ 35 Mio. cycles with PLC load	Unlimited
Power-up pulse suppression		–	Yes
Protection for inductive load		–	Yes
Mechanical characteristics	Unit	Type RST	Type EST
Housing		Plastic / PA66 + PA6I red	
Cable cross section	mm ²	2 x 0.14	3 x 0.14
Cable type*		PUR, black	PUR, black
Bending radius	mm	≥ 36	≥ 30
Weight (Mass)	kg	ca. 0.030 RST-K ca. 0.010 RST-S	ca. 0.030 EST-K ca. 0.010 EST-S
Degree of protection	IP	67 to DIN EN 60529	
Ambient temperature range**	°C	-25°C to +80°C	
– with adapter	°C	-25°C to +60°C	
Adapter tightening torque	Nm	0.15 (tightening torque of screwing adapter onto magnetic switch)	
Shock resistance			
Vibration to EN 60068-2-6	G	15, 11 ms, 10 to 55 Hz, 1 mm	
Shock to EN 60068-2-27	G	50, 11 ms	
Bump to EN 60068-2-29	G	30, 11 ms, 1000 bumps each axis	

B	Electronic Sensors
	Actuator Products
Selection Guide	
Drop-in Sensors	
Solid State / Reed Sensors	
Weld Immune Sensors	
Cordset / Connect Block	
NAMUR Sensors	
Proximity Sensors	

Ordering Information

Version	Voltage	Type	Order number
Magnetic switch, reed contact, normally open, LED indicator, cable 2 m	10-30 V AC / DC	RST-K	KL 3301
Magnetic switch, reed contact, normally open, LED indicator, cable 5 m	10-30 V AC / DC	RST-K	KL 3300
Magnetic switch, reed contact, normally open, snap connector M8, LED indicator, cable 0.24 m	10-30 V AC / DC	RST-S	KL 3302
Magnetic switch, reed contact, normally open, screw connector M8, LED indicator, cable 0.24 m	10-30 V AC / DC	RST-S	KL 3303
Magnetic switch, reed contact, normally closed, cable 5 m	10-30 V AC / DC	RST-K	KL 3305
Magnetic switch, electronic, PNP LED indicator, cable 2 m	10-30 V DC	EST-K	KL 3308
Magnetic switch, electronic, PNP LED indicator, cable 5 m	10-30 V DC	EST-K	KL 3309
Magnetic switch, electronic, PNP snap connector M8, LED indicator	10-30 V DC	EST-S	KL 3312
Magnetic switch, electronic, PNP screw connector M8, LED indicator	10-30 V DC	EST-S	KL 3306

Included in delivery: 1 magnetic switch
 1 adapter for dovetail groove mounting

Accessories

Description	Type	Order number
Cable M8, 2.5 m without lock nut	KS 25	KY 3240
Cable M8, 5.0 m without lock nut	KS 50	KY 3241
Cable M8, 10.0 m without lock nut	KS 100	KY 3140
Cable M8, 2.5 m with lock nut	KSG 25	KC 3102
Cable M8, 5.0 m with lock nut	KSG 50	KC 3104
Adapter for dovetail groove (pack of 10)		KL 3333

B

Electronic Sensors
 Actuator Products

Selection
 Guide

Drop-in
 Sensors

Solid State /
 Reed Sensors

Weld Immune
 Sensors

Cordset/
 Connect Block

NAMUR
 Sensors

Proximity
 Sensors



P1A Series Solid State Sensors

These sensors are of solid-state type, with no moving parts. Short-circuit and transient protection is incorporated as standard. The integral electronics make these sensors suitable for applications with very high switching frequencies.

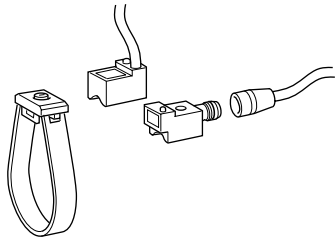

Wiring connection

P1A-2XMK

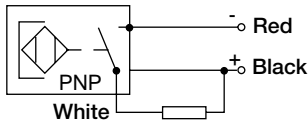

P1A-2XLK

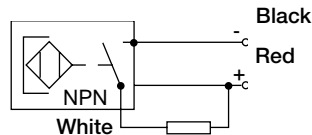

P1A-2XHK, P1A-2XJH

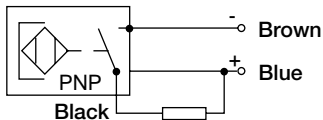

P1A-2XEK, P1A-2XFH

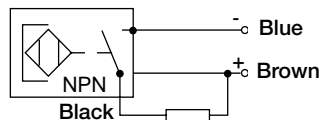

P1A Series Reed Sensors

The reed sensors incorporate a well-proven, universal-voltage, compact reed switch element; making them suitable for a wide range of applications. They can work with electronic control systems or conventional relay systems.

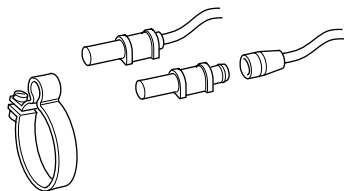

Wiring connection

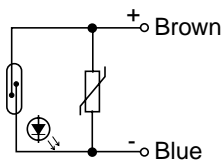

Electronic Sensors

Output	Cable length	Weight (lb)	Part number
PNP, N.O.	2 m	0.09	P1A-2XMK, Rt. angle
NPN, N.O.	2 m	0.09	P1A-2XLK, Rt. angle
PNP, N.O.	2 m	0.022	P1A-2XHK
NPN, N.O.	2 m	0.022	P1A-2XEK
PNP, N.O.	*	0.033	P1A-2XJH
NPN, N.O.	*	0.033	P1A-2XFH

Mounting Brackets

Fits cylinder bore size	Weight (lb)	Part number
10mm	0.01	P1A-2CCC
12mm	0.01	P1A-2DCC
16mm	0.0176	P1A-2FCC
20mm	0.0176	P1A-2HCC
25mm	0.022	P1A-2JCC

Cable for Sensors

Cable length	Weight (lb)	Part number
3 m	0.12	9126344341**
10 m	0.4	9126344342**

* Cable ordered separately

** Cable includes female part connector for sensor

Electronic Sensors

Output	Cable length	Weight (lb)	Part number
Making (N.O.)	3m	0.12	P1A-2XRL
Making (N.O.)	*	0.004	P1A-2XSH

Mounting Brackets

Fits cylinder bore size	Weight (lb)	Part number
10mm	0.004	P1A-2CCB
12mm	0.005	P1A-2DCB
16mm	0.006	P1A-2FCB
20mm	0.009	P1A-2HCB
25mm	0.010	P1A-2JCB

Cable for Sensors

Cable length	Weight (lb)	Part number
3 m	0.12	9126344341**
10 m	0.4	9126344342**

* Cable ordered separately

** Cable includes female part connector for sensor

B
 Electronic Sensors
 Actuator Products
 Selection Guide
 Drop-in Sensors
 Solid State / Reed Sensors
 Weld Immune Sensors
 Cordset / Connect Block
 NAMUR Sensors
 Proximity Sensors



LP/LPM Series Sensors

Bore size	Reed (Low AMP)	NPN sinking	PNP sourcing
9/16"	L077030000	L076950000	L076990000
3/4", 1-1/8"	L077040000	L076960000	L077000000
1-1/2", 2"	L077050000	L076970000	L077010000
2-1/2", 3", 4"	L077060000	L076980000	L077020000

Note: For sensors with an 8mm connector, replace the last digit with a 'C'. For example: L07696000C.

Circuits

Reed Sensor

NOTE: Polarity must be observed for DC operation only.

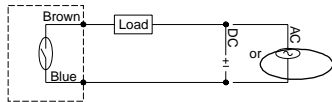

*Number in parentheses pertains to inductive loads.

NPN Sensor – Sinking Output

Color of Cable Black
 "On" State Voltage Drop 1.5V Maximum



PNP Sensor – Sourcing Output

Color of Cable Black
 "On" State Voltage Drop 1.5V Maximum

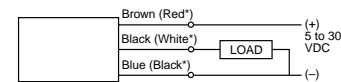

Circuit for Switching Contact Protection (Inductive Loads) – for Reed Sensor Only
(Required for proper operation 24V DC)

Put Diode parallel to load (CR) following polarity as shown below.

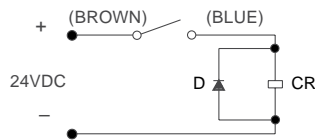

D: Diode: select a Diode with the breakdown voltage and current rating according to the load.

Typical Example – 100 Volt, 1 Amp Diode
 CR: Relay coil (under 0.5W coil rating)
 (Recommended for longer life 125 VAC)

*Wire colors in parentheses pertain to sensors manufactured before 10/15/93.

Put a resistor and capacitor in parallel with the load (CR). Select the resistor and capacitor according to the load.

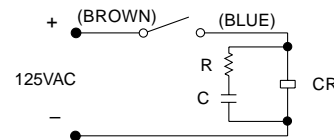

Typical Example:
 CR: Relay coil (under 2W coil rating)
 R: Resistor 1 KΩ – 5 KΩ, 1/4 W
 C: Capacitor 0.1 μF, 600 V

⚠ Caution

- Use an ammeter to test reed sensor current. Testing devices such as incandescent light bulbs may subject the reed sensor to high in-rush loads.
- NOTE: When checking an unpowered reed sensor for continuity with a digital ohmmeter the resistance reading will change from infinity to a very large resistance (2 M ohm) when the sensor is activated. This is due to the presence of a diode in the reed sensor.
- Anti-magnetic shielding is recommended for reed sensors exposed to high external RF or magnetic fields.
- The magnetic field strength of the piston magnet is designed to operate with our sensors. Other manufacturers' sensors may not operate correctly in conjunction with these magnets.

- Current capabilities are relative to operational temperatures.
- Use relay coils for reed sensor contact protection.
- The operation of some 120 VAC PLC's (especially some older Allen-Bradley PLC's) can overload the reed sensor. The sensor may fail to release after the piston magnet has passed. This problem may be corrected by the placement of a 700 to 1K OHM resistor between the sensor and the PLC input terminal. Consult the manufacturer of the PLC for appropriate circuit.
- Sensors with long wire leads (greater than 15 feet) can cause capacitance build-up and sticking will result. Attach a resistor in series with the reed sensor (the resistor should be installed as close as possible to the sensor). The resistor should be selected such that R (ohms) > E/0.3.

PRNA Sizes 3 to 30 Sensors

Fixed position sensor

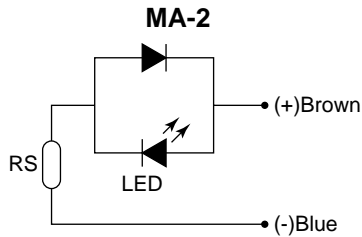

Variable position sensor

Size	Part number
1	FR-1PRN
3	FR-3PRN
10	FR-10PRN
20	FR-20PRN
30	FR-30PRN

Model code and ordering information

Example: SR20 - 180 - 90

SR	20	180	90
Size	Rotation	Reference point	
3	090 90°	45	45°
10	100 100°	90	90°
20	180 180°		
30	270 270°		

B
 Electronic Sensors
 Actuator Products
 Selection Guide
 Drop-in Sensors
 Solid State / Reed Sensors
 Weld Immune Sensors
 Cordset / Connect Block
 NAMUR Sensors
 Proximity Sensors

PRN Sizes 50 to 800 Sensors

Solid state sensors

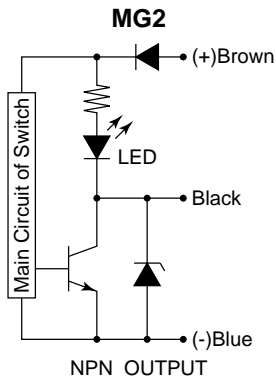

Reed sensors

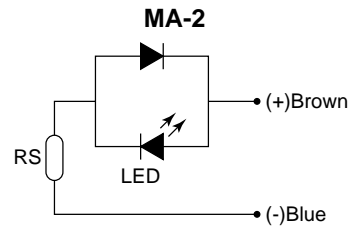

Model code and ordering information

Example: FM50 - 90 - 45 - MA 2

FM	50	90	45	MA	2
Size	Rotation	Reference point		Sensor type	Number sensors
50	090 90°	45	45°	MA Reed	2 Standard
150	180 180°	90	90°	MG Solid State	
300	270 270°				
800					

Solid State (Hall Effect) Sensors

Type	LED color	Logic	Cable/Connector	Part number
N.O.	Green	PNP	1.5m black with leads	SMH-1P
N.O.	Red	NPN		SMH-1N
N.C.	Yellow	PNP		SMC-1P
N.C.	White/Red	NPN	0.15m black with connector	SMC-1N
N.O.	Green	PNP		SMH-1PC
N.O.	Red	NPN		SMH-1NC
N.C.	Yellow	PNP	SMC-1PC	
N.C.	White/Red	NPN	SMC-1NC	

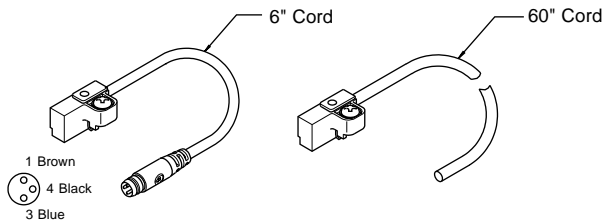

Wiring connection

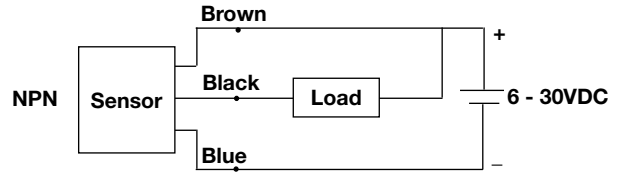
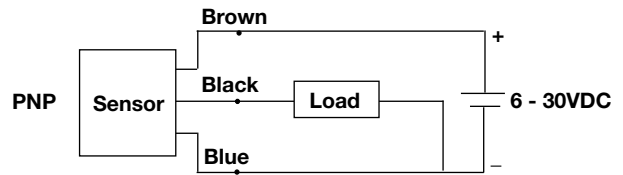

Protection circuit*

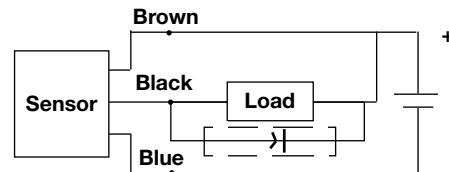

* When connecting an inductive load (relay, solenoid valve, etc.), a protection circuit is recommended. Use a 100V, 1A diode. (NPN connection shown.)

Reed Sensors

Reed sensors are available in a normally open or normally closed configuration. The low amp sensor is suitable for connection to PLCs or other low current devices. The high amp sensor can be used to drive sequencers, relays, coils, or other devices directly.

Type	LED color	Rating	Cable/Connector	Part number
N.O.	Green	High Amp	1.5m Gray with Leads	SMR-1
N.O.	Red	Low Amp		SMR-1L
N.C.	Yellow	Low Amp	0.15m Gray with Connector	SMD-1L
N.O.	Green	High Amp		SMR-1C
N.O.	Red	Low Amp	SMR-1LC	
N.C.	Yellow	Low Amp	SMD-1LD	

Integral circuit for switching contact protection

(Required for proper operation 24V DC)
 Put Diode parallel to load (CR) with polarity as shown below.

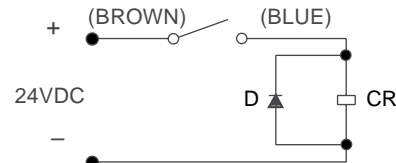

D: Diode: select a Diode with the breakdown voltage and current rating according to the load.

CR: Relay coil (under 0.5 W coil rating)

(Recommended for longer sensor life 125V AC)
 Put resistor and capacitor parallel to load (CR).

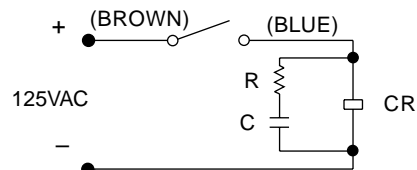

CR: Relay coil (under 2 W coil ratings)

R: Resistor under 1 K ohm

C: Capacitor 0.1 µF



Solid State (Hall Effect) Sensors

PTR model	PNP		NPN	
	With 6" male quick connect	With 39" potted-in leads	With 6" male quick connect	With 39" potted-in leads
10	SWH-1PC	SWH-1P	SWH-1NC	SWH-1N
15	SWH-1PC	SWH-1P	SWH-1NC	SWH-1N
20	SWH-2PC	SWH-2P	SWH-2NC	SWH-2N
25	SWH-2PC	SWH-2P	SWH-2NC	SWH-2N
32	SWH-2PC	SWH-2P	SWH-2NC	SWH-2N

Note: Sensors with male quick connect option require female cordsets to be ordered separately. Please reference catalog 0900P-E, page M22.

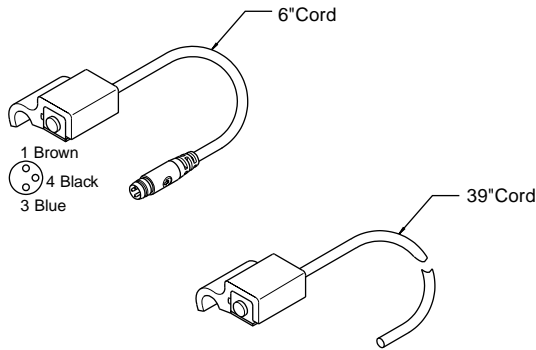

Wiring connection

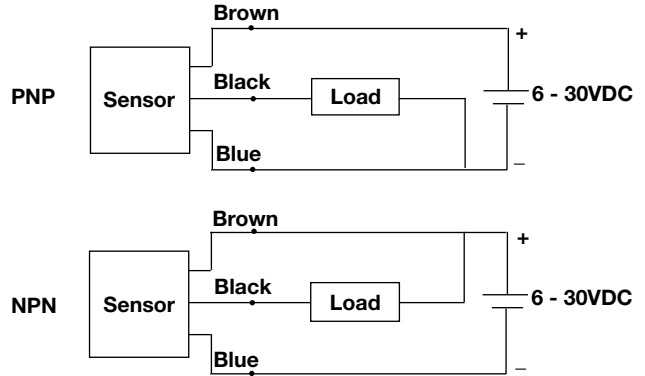

Protection circuit*

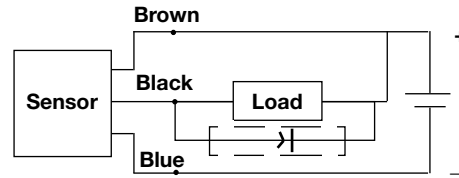

* When connecting an inductive load (relay, solenoid valve, etc.), a protection circuit is recommended. Use a 100V, 1A diode. (NPN connection shown.)

Reed Sensors

PTR model	With 6" male quick connect	With 39" potted-in leads
10	SWR-1C	SWR-1
15	SWR-1C	SWR-1
20	SWR-2C	SWR-2
25	SWR-2C	SWR-2
32	SWR-2C	SWR-2

Sensors with male quick connect option require female cordsets to be ordered separately.

Note: Please reference catalog 0900P-E, page M22

Protection circuit (Inductive loads)

(Required for proper operation 24VDC)

Select a diode with a breakdown voltage and current rating according to the load (CR). Place a diode in parallel to the load with the polarity as indicated:

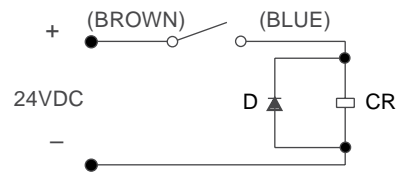

CR: Relay coil (under 0.5W coil rating)

(Recommended for longer sensor life 125VAC)

Select a resistor and capacitor according to the load (CR). Place a resistor and capacitor in parallel to the load:

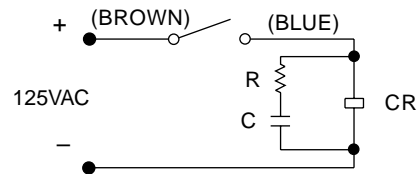

CR: Relay coil (under 2W coil rating)

R: Resistor under 1 K ohm

C: Capacitor 0.1 μF

B
 Electronic Sensors
 Actuator Products
 Selection Guide
 Drop-in Sensors
 Solid State / Reed Sensors
 Weld Immune Sensors
 Cordset / Connect Block
 NAMUR Sensors
 Proximity Sensors



Weld Immune Sensors



- Weld immune in all welding applications (AC, DC and medium frequency welding).
- Sensor locks the output during the welding process; when welding process stops, the sensor updates the output accordingly.
- NOTE: Tie rod construction of the P1D Series can be ordered directly in the model code.

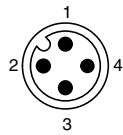

Pin	Function
1	Operating voltage (+VDC)
4	Output signal (N.O.)
3	-VDC
2	Not used

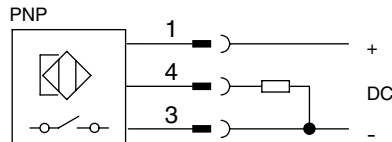

Description	Part number
Weld immune sensor	0886600000
Tie rod bracket kit	0886620000

0886600000

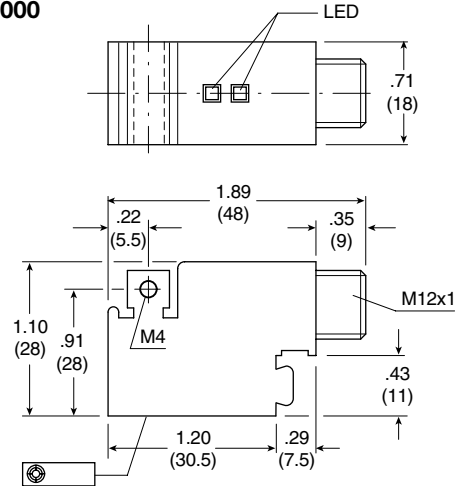

0886620000

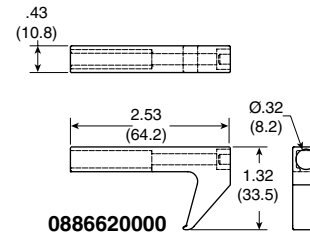

Air Piloted Switch

Features	
Type	3/2 valve - NC, 2-position / spring return 3-way
Applicable series	AZ, AZV
Construction materials	
Body	Macrolon, glass fiber
Mounting bracket	Aluminum, anodized
Connection	3 - 3mm OD barbs
Characteristics	
Operating temperature	14°F to 140°F (-10°C to +60°C)
Operating pressure	30 PSI to 90 PSI (2 bar to 6 bar)
Normal operating pressure	90 PSI (6 bar)
Flow	0.04 Cv (40 l/min)
Cycle rate	40 hz
Switching accuracy	± 0.008" (0.2 mm) w/o air
Filtration	40 micron
Media	Filtered and regulated compressed air
Installation	In any position
Weight	Sensor 0.49 ozs (0.014 Kg) Sensor & bracket 0.99 Ozs (0.028 Kg)

Description	Part number
Sensor – Air type	KZ 2364
Mounting bracket	KZ 8255

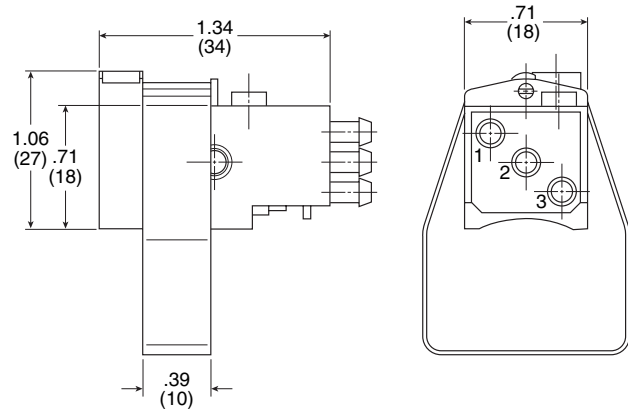

8mm Cordset with Female Quick Connect

A female connector is available for all sensors with the male 8mm quick connect option. The male plug will accept a snap-on or threaded connector. Cordset part numbers are listed below:

Cable length	Threaded connector	Snap on connector
5 meters	086620T005	086620S005
2 meters	086620T002	086620S002

Snap-On Straight Connector

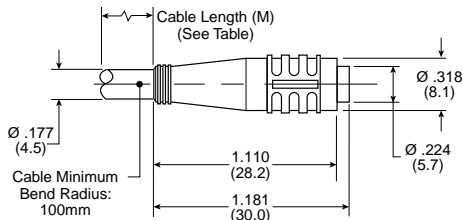

Cordset Specifications

Connector Oil resistant polyurethane body material, PA 6 (Nylon) contact carrier, spacings to VDE 0110 Group C, (150 AC/DC)
 ContactsGold plated beryllium copper, machined from solid stock
 Coupling Method..... Snap-Lock or chrome plated brass nut
 Cord Construction Oil resistant black PUR jacket, non-wicking, non-hygroscopic, 300V.
 Cable end is stripped and tinned.
 ConductorsExtra high flex stranding, PVC insulation
 Temperature -40 to 194°F (-40 to 90°C)
 Protection..... NEMA 1, 3, 4, 6P and IEC 1P67
 Cable Length..... 6.56 ft (2m) or 16.4 ft (5m)

Threaded Straight Connector

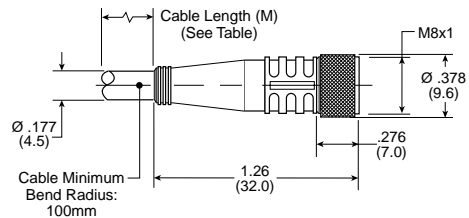

12mm Cordset with Female Quick Connect

M12 Straight connector

Cable length	Part number
5 meters	9126487205
2 meters	9126487202

M12 Right angle Connector

Cable length	Part number
5 meters	9126487205
2 meters	9126487202

A female connector is available for all sensors with the male 12mm quick connect option. The cordsets are available with a right angle or straight connector. Cordset part numbers are listed above.

Cordset Specifications

Connector Polyvinylchloride (PVC) body material, PVC contact carrier, spacing to VDE 0110 Group C, (250VAC / 300VDC)
 Contacts Gold Plated Copper Tin (CuSn), stamped from stock.
 Coupling Method..... Threaded nut: Chrome plated brass.
 Cord Construction PVC non-wicking, non-hygroscopic, 250VAC / 300VDC. Cable end is stripped.
 Conductors Extra high flex stranding with PVC insulation
 Temperature -13°F to 158°F (-25°C to 70°C)
 Protection..... NEMA 1, 3, 4, 6P and IEC 1P67
 Cable Length..... 6.56 ft (2m) or 16.4 ft (5m)

Straight Connector

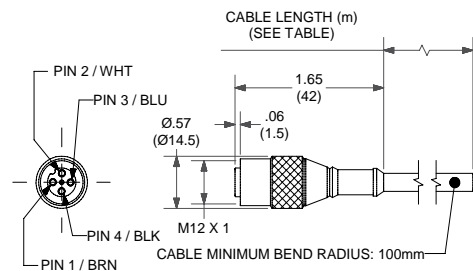

Right Angle Connector

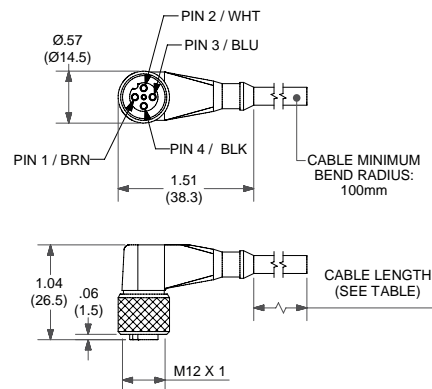

B
 Electronic Sensors
 Actuator Products
 Selection Guide
 Drop-in Sensors
 Solid State / Reed Sensors
 Weld Immune Sensors
 Cordset / Connect Block
 NAMUR Sensors
 Proximity Sensors



NAMUR Intrinsically Safe Sensors



For Tie Rod Style Cylinders

Sensor description	Part number
Fits 1-1/8" to 4" bore and 32-100mm bore (2m flying lead)	089779001
Fits 1-1/8" to 4" bore and 32-100mm bore (12mm connector)	089779002
Fits 5" to 6" bore and 125-160mm bore (2m flying lead)	089779003
Fits 5" to 6" bore and 125-160mm bore (12mm connector)	089779004
Fits 8" bore and 200mm bore (2m flying lead)	089779005
Fits 8" bore and 200mm bore (12mm connector)	089779006

Specifications

Electrical configuration.....	NAMUR 2-wire
Output function	NAMUR
Supply voltage.....	5-25 VDC
Response sensitivity	≤ 30 Gauss
Switching frequency	5 kHz
Switching output	Control current dependent on switching
Residual ripple.....	≤ 5% of supply voltage
Power consumption, attenuated.....	≥ 2.5mA
Power consumption, unattenuated.....	≤ 1mA
Internal capacitance	≤ 15nF
Internal inductance	≤ 25 μH
Cable resistance.....	≤ 50 Ohm
Hysteresis.....	≤ 1mm
Repeatability.....	≤ 0.1mm
EMC.....	EN 60 947-5-6
Short circuit protected.....	Yes
Reverse polarity protected.....	Yes
Enclosure rating.....	IP67
Shock/vibration stress	30 g, 11ms, 10-55 Hz, 1mm
Operating temperature	-25°C to +70°C (-13°F to +158°F)
Housing material.....	Aluminum, plastic
Connector cable.....	PVC with flying leads (shown)
Connector (option).....	M12 connector
Classification	TÜV 99 ATEX 1398 II 2G EEx ib IIC T6

Wiring connection

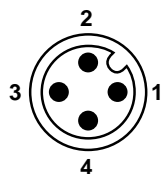

Pin	Wire	Function
1	Brown	Operating voltage (+VDC)
4	Blue	-VDC
2		Not used
3		Not used

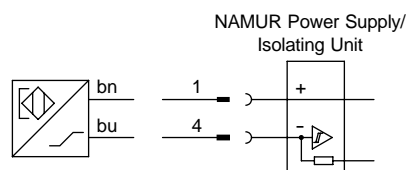

Data for connecting power supplies or other approved isolating amplifiers:

Short circuit current 1Kmax	≤ 30mA
No load voltage	≤ 16VDC
Power loss	≤ 75mW

Note: Intrinsically safe solutions must include a NAMUR Power Supply

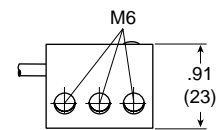
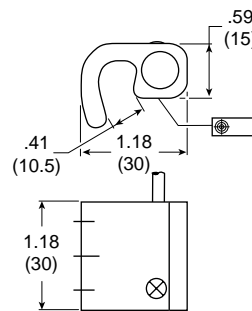

0897790001

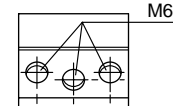
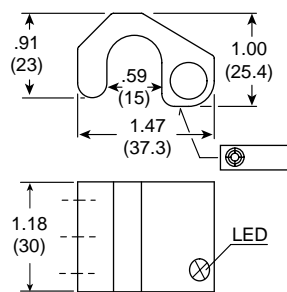

0897790003

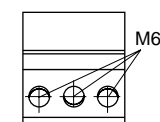
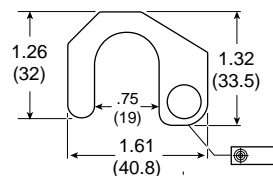

0897790005

B

Electronic Sensors
 Actuator Products

Selection
 Guide

Drop-in
 Sensors

Solid State /
 Reed Sensors

Weld Immune
 Sensors

Cordset/
 Connect Block

NAMUR
 Sensors

Proximity
 Sensors

NAMUR Intrinsically Safe Sensors



For Round Body Cylinders

Description	Part number
NAMUR Sensor for round body cylinder	0897790007
Bracket for 18-29mm (0.71"-1.14") outer diameter	0897800001
Bracket for 28-39mm (1.10"-1.54") outer diameter	0897800002
Bracket for 38-49mm (1.50"-1.93") outer diameter	0897800003
Bracket for 48-59mm (1.89"-2.32") outer diameter	0897800004
Bracket for 58-69mm (2.28"-2.72") outer diameter	0897800005
Bracket for 68-79mm (2.68"-3.11") outer diameter	0897800006
Bracket for 88-99mm (3.46"-3.90") outer diameter	0897800007
Bracket for 98-109mm (3.86"-4.29") outer diameter	0897800008

Specifications

Electrical configuration.....	NAMUR 2-wire
Output function	NAMUR
Supply voltage.....	5-25 VDC
Response sensitivity	≤ 30 Gauss
Switching frequency	5 kHz
Switching output	Control current dependent on switching
Residual ripple.....	≤ 5% of supply voltage
Power consumption, attenuated.....	≥ 2.5mA
Power consumption, unattenuated.....	≤ 1mA
Internal capacitance	≤ 15nF
Internal inductance	≤ 25 μH
Cable resistance.....	≤ 50 Ohm
Hysteresis.....	≤ 1mm
Repeatability.....	≤ 0.1mm
EMC.....	EN 60 947-5-6
Short circuit protected.....	Yes
Reverse polarity protected.....	Yes
Enclosure rating.....	IP67
Shock/vibration stress	30 g, 11ms, 10-55 Hz, 1mm
Operating temperature	-25°C to +70°C (-13°F to +158°F)
Housing material.....	Aluminum, plastic
Connector cable.....	PVC with flying leads (shown)
Classification	TÜV 99 ATEX 1398 II 2G EEx ib IIC T6

Data for connecting power supplies or other approved isolating amplifiers:

Short circuit current 1Kmax	≤ 30mA
No load voltage	≤ 16VDC
Power loss	≤ 75mW

Note: Intrinsically safe solutions must include a NAMUR Power Supply

0897790007

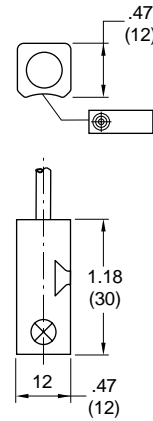

Round Body Brackets

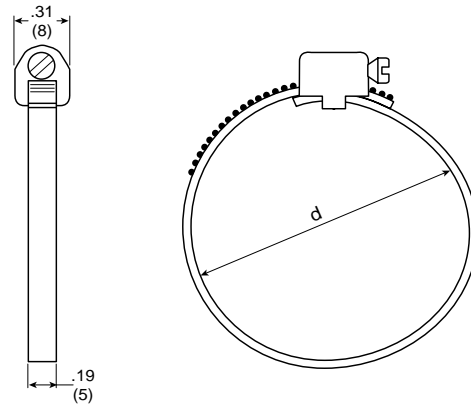

Wiring connection

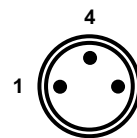

Pin	Wire	Function
1	Brown	Operating voltage (+VDC)
3	Blue	-VDC
4		Not used

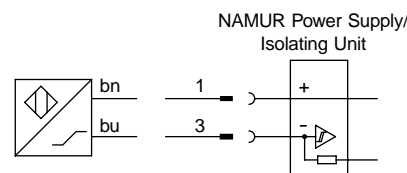

B

Electronic Sensors
 Actuator Products

Selection
 Guide

Drop-in
 Sensors

Solid State/
 Reed Sensors

Weld Immune
 Sensors

Cordset/
 Connect Block

NAMUR
 Sensors

Proximity
 Sensors

NAMUR Sensor Power Supply



For All NAMUR Sensors

Supply voltage	Part number
115VAC	0897810001
230VAC	0897810002
24VDC	0897810003

- Reliable DC-decoupling between input, output and supply voltage in accordance with VDE 0100 Part 410
- 2-channel with one relay output SPDT respectively
- Intrinsically safe inputs complying with [EEx 1a] IIC
- Housing with snap fastening for support rail DIN 46277

Specifications

Supply voltage..... 115 VAC (p/n 0897810001)
 230 VAC (p/n 0897810002)
 24 VDC (p/n 0897810003)

Mains frequency48-62 Hz

Switching frequency ≤ 20 Hz

Power consumption per channel Approximately 1.5 VA
 Approximately 0.7 W only for p/n 0897810003

Inputs 2 sensors

No load voltage 8.5 VDC

Short circuit current ≥ 6mA

Permissible external capacitance ≤ 567nF

Permissible external inductance ≤ 5 mH

Switching outputs..... 1 relay per input: SPDT

Switching voltage ≤ 250 VAC

Switching current..... ≤ 5 A

Switching output ≤ 100 VA

Permit..... PTB no. Ex-95.C.2003X

VDE protection class I

Enclosure rating..... IP20

Operating temperature -25°C to +60°C (-13°F to +140°F)

Approximate weight..... 250g (8.8 oz.)

Housing material..... Plastic

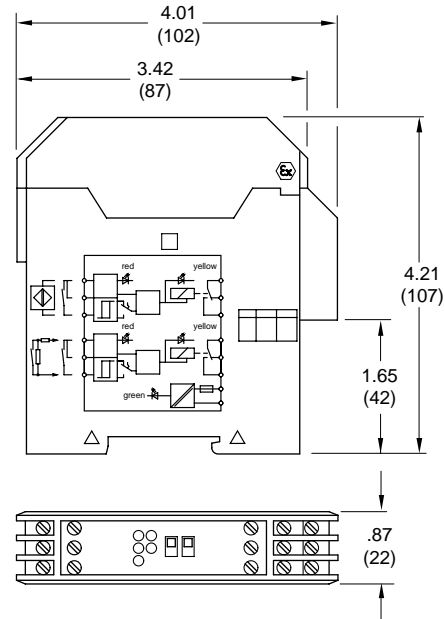

B

Electronic Sensors
Actuator Products

Selection
Guide

Drop-in
Sensors

Solid State /
Reed Sensors

Weld Immune
Sensors

Cordset /
Connect Block

NAMUR
Sensors

Proximity
Sensors

End-of-Stroke Proximity Sensors

Ordering information

Sensor type	Inductive proximity			Non-contacting magnetically actuated	
Style	EPS-7	EPS-5	EPS-6	CLS-1	CLS-4
Sensor part number	148897****	146617****	148896****	148275****	149109****
6' Cable	0853550006	0853550006	0859170006	0853550006	—
12' Cable	0853550012	0853550012	0859170012	0853550012	—
6' Cable, right angle	0875470006	0875470006	—	0875470006	—

**** Part number suffix: **** 4-digit suffix indicates probe length: 0125=1.25", 0206=2.06", 0288=2.875", 0456=4.562"

Specifications

Style	EPS-7	EPS-5	EPS-6	CLS-1	CLS-4
Code designator	H	R	D	F	B
Sensor type	Inductive proximity	Inductive proximity	Inductive Proximity	Non-contacting magnetically actuated	Non-contacting magnetically actuated
Description	Economical, General Purpose, 2 wire device, primarily for AC applications, not suitable for 24 VDC applications. Use EPS-5 only for automotive industry customers who specify them.		Economical, General Purpose, 3 wire, DC sensor, dual output: sinking and sourcing	Functional replacement for AB (Mechanical) Limit Switches in many applications, or where customer needs NC contacts, zero leakage, zero voltage drop, higher or lower load current than EPS-style.	Functional replacement for AB (Mechanical) Limit Switches in many High Temperature applications, or where customer needs NC contacts, zero leakage, zero voltage drop, higher or lower load current than EPS-style.
Supply voltage	20 to 250 VAC/DC	20 to 230 VAC/DC	10 to 30 VDC	24 to 240 VAC/DC	24 to 240 VAC/DC
Load current, min	8 mA	5 mA	NA	NA	NA
Load current, max	300 mA	500 mA	200 mA	4 AMPS @ 120 VAC 3 AMPS @ 24 VDC	4 AMPS @ 120 VAC 3 AMPS @ 24 VDC
Leakage current:	1.7 mA, max.	1.7 mA, max.	10 micro amps max.	—	—
Voltage drop	7 V, max.	10 V, max	2 VDC max.	NA	NA
Operating temperature	-14° to 158° F	-4° to 158° F	-14° to 158° F	-40°F to 221° F	-40° F to 400° F
Connection	3-pin mini	3-pin mini	5-pin mini	3-pin mini	144" PTFE coated flying leads with 1/2" conduit hub
Enclosure rating	IEC IP67	NEMA 4, 6, 12, 13	IEC IP67	NEMA 1, 2, 3, 4, 4x, 5, 6, 6P, 11, 12, 12K, 13	NEMA 1, 2, 3, 4, 4x, 5
Led indication	Yes	Yes	Yes	No	No
Short circuit protection	Yes	Yes	Yes	No	No
Weld field immunity	Yes	Yes	Yes	Yes	Yes
Output	2 wire, Normally Open with leakage current	2 wire, Normally Open with leakage current	Dual output: DC Sinking and DC Sourcing, user selectable via wiring	SPDT (Single pole double throw), Normally Open/Normally Closed, Form C	SPDT (Single pole double throw), Normally Open/ Normally Closed, Form C
Approvals / marks	CE, UL, CSA	UL	CE, UL, CSA	UL or CSA	UL or CSA
Make / break location	0.125" from end of stroke, typical. Tolerance is 0/-0.125"				
Wiring instructions	Pin 1: AC ground (Green)	Pin 1: AC ground (Green)	Pin 1: +10 to 30 VDC (White)	Pin 1: Common (Green)	Common: (Black)
	Pin 2: Output (Black)	Pin 2: Output (Black)	Pin 2: Sourcing output (Red)	Pin 2: Normally Closed (Black)	Normally Open: (Blue)
	Pin 3: AC line (White)	Pin 3: AC line (White)	Pin 3: Grounded (not connected or required)	Pin 3: Normally Open (White)	Normally Closed: (Red)
			Pin 4: Sinking output (Orange)		
			Pin 5: DC common (Black)		

B
Electronic Sensors
Actuator Products
Selection Guide
Drop-in Sensors
Solid State / Reed Sensors
Weld Immune Sensors
Cordset / Connect Block
NAMUR Sensors
Proximity Sensors



Series and Parallel Wiring

When Parker EPS-5, 6 or 7 proximity sensors are used as inputs to programmable controllers, the preferred practice is to connect each sensor to a separate input channel of the PC. Series or parallel operations may then be accomplished by the internal PC programming.

Parker EPS-5, 6 or 7 sensors may be hard wired for series operation, but the voltage drop through the sensors (see specifications) must not reduce the available voltage below what is needed to actuate the load.

Parker EPS-5, 6 or 7 sensors may also be hard wired for parallel operation. However, the leakage current of each sensor will pass through the load. The total of all leakage currents must not exceed the current required to actuate the load. In most cases, the use of two or more EPS-5, 6 or 7 sensors in parallel will require the use of a bypass (shunt) resistor.

EPS-5
Automotive Applications

(Meets some Automotive Manufacturer's Specifications)

Series	A max.	C max.
2A, 4MA, 4MAJ	1.55"	1.30"

For exact dimensions, see Bulletin 0840-G-E1

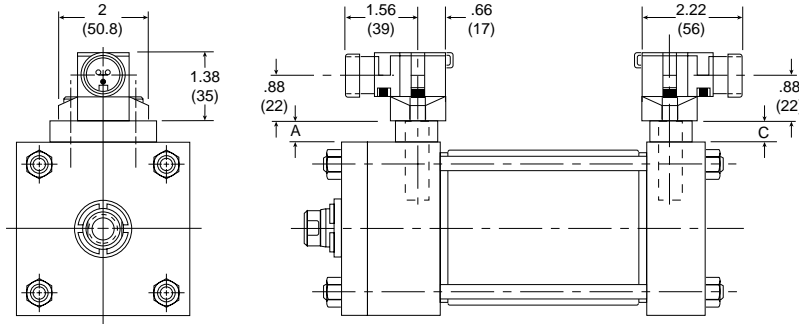

EPS-7 & EPS-6 sensors

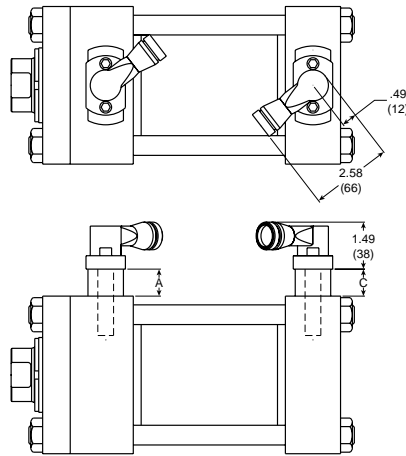

CLS-1 & 4 sensors

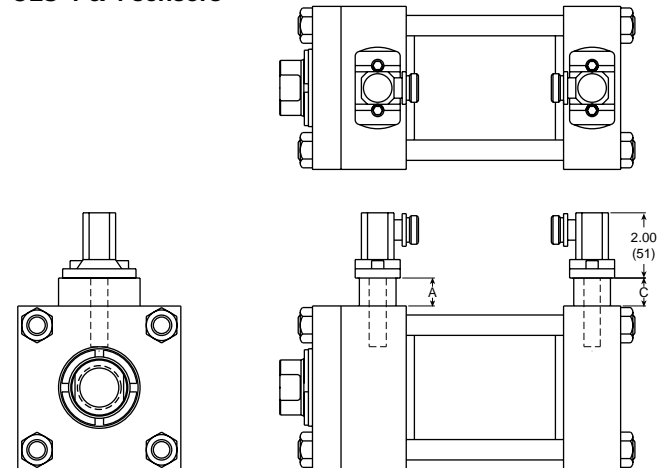

Connector pin numbering

3-pin mini

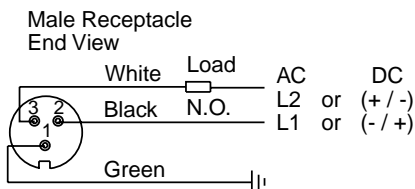

5-pin mini

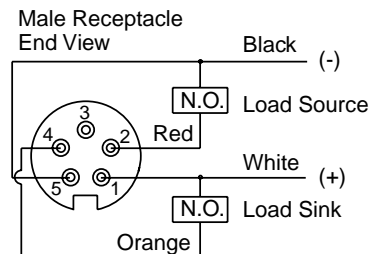

B

Electronic Sensors
 Actuator Products

Selection
 Guide

Drop-in
 Sensors

Solid State /
 Reed Sensors

Weld Immune
 Sensors

Cordset/
 Connect Block

NAMUR
 Sensors

Proximity
 Sensors

How to Specify EPS Sensors

Parker EPS proximity sensors may be ordered on 2A, 2AN, 4MA and 4MAJ Series cylinders as follows:

- 1) Complete the basic cylinder model number.
- 2) Place an "S" in the model number to denote sensors and/or special features.
- 3) Mounting styles D, DB, JB, or HB should be used with caution because of possible mounting interferences. Consult bulletin 0840-G-E1 for additional information.
- 4) Special modifications to cylinders other than sensors must have a written description.

- 5) Specify letter prefix "H" for EPS-7, "D" for EPS-6, "R" for EPS-5, "F" for CLS-1, or "B" for CLS-4, then fill in the four fields specifying port location, sensor orientation and actuation point for both head and cap. If only one sensor is used, place "XXXX" in the unused fields.

Example = H13CGG-XXXX denotes a sensor on the head end only, EPS-7

Example = BXXXX-42BGG denotes a sensor on the cap end only, CLS-4

B
Electronic Sensors
Actuator Products
Selection Guide
Drop-in Sensors
Solid State / Reed Sensors
Weld Immune Sensors
Cordset / Connect Block
NAMUR Sensors
Proximity Sensors

Head end

R	1	3	A	GG
Specify:	Port Location	Sensor Location	Sensor Orientation	Actuation Point
R = EPS-5	See Figure 1.	See Figure 1.	See Figure 2 for EPS-7 and EPS-6 only.	GG = End of Stroke
H = EPS-7				See Bulletin 0840-G-E1 for stroke remaining.
D = EPS-6				
F = CLS-1				
B = CLS-4				
N = Prep for sensors only				

Cap end

4	2	B	GG
Port Location	Sensor Location	Sensor Orientation	Actuation Point
See Figure 1.	See Figure 1.	See Figure 2 for EPS-7 and EPS-6 only.	GG = End of Stroke
			See Bulletin 0840-G-E1 for stroke remaining.

Note: All specified sensor and port locations are as seen from rod end of cylinder.
 *EPS-5 sensors will be oriented so that the connectors face each other.
 **Consult the Wadsworth, Ohio facility for this option with 4MA and 4MAJ Series cylinders.

Figure 1

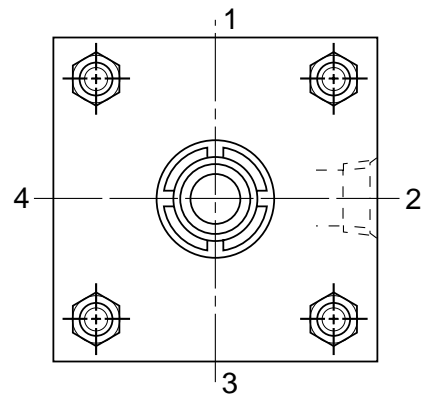
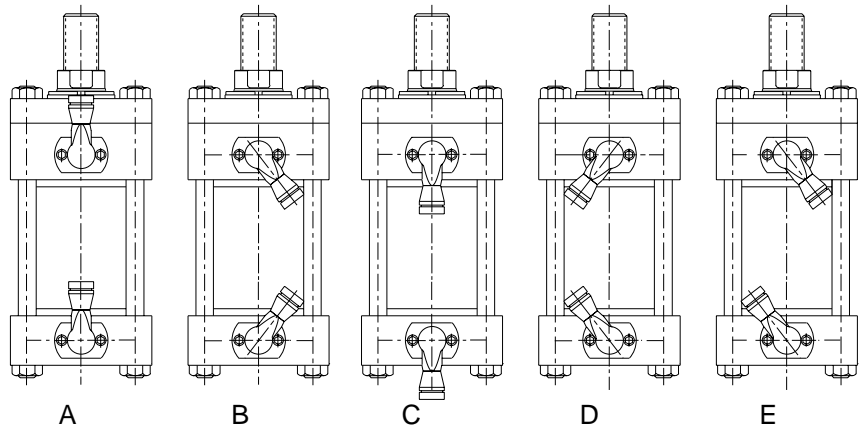

Figure 2



Example:
 4.00 CJ4MAUS14AC 12.000
 S = H13CGG-13CGG

EPS-5 & EPS-7

Connectors

The male quick disconnect on the Parker EPS-5 or 7 is a Brad Harrison 40909 connector.

Female connects must be purchased with one of the following cable lengths.

Cable length	Part number	
	Automotive	Standard
3'	085356003	0853550003
6'	085356006	0853550006
9'	085356009	—
12'	085356012	0853550012

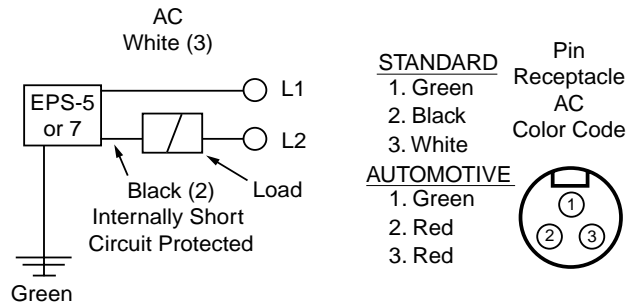

EPS-6

Connectors

The male quick disconnect on the Parker EPS-6 is a Brad Harrison 41310 connector.

Plug Pin and Cable Identification

- 1) +10 to 30 VDC (White)
- 2) Source (Red)
- 3) Grounded not connected nor required
- 4) Sink (Orange)
- 5) Common (Black)

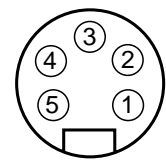
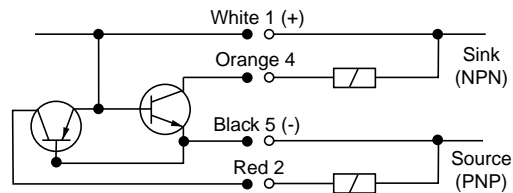

Cable length	Part number
3	0859170003
6	0859170006
12	0859170012

LED Function	"Ready"	"Target"
Power Applied (No Target)	ON	OFF
Target Present	OFF	ON
Short Circuit Condition	FLASH	FLASH

CLS

Connectors

The male quick disconnect on the Parker CLS-1 is a Brad Harrison 40909 connector.

Female connects must be purchased with one of the following cable lengths.

Cable length	Part number
3'	0853550003
6'	0853550006
9'	—
12'	0853550012

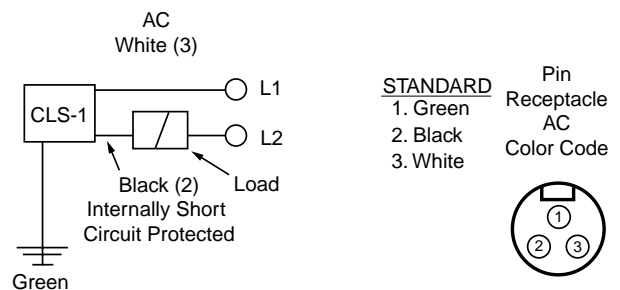

The connection for the CLS-4 are 144" PTFE insulated flying leads with 1/2" conduit hub. 3-wire: Common (black), Normally open (blue), and Normally closed (red).

B

Electronic Sensors
 Actuator Products

Selection
 Guide

Drop-in
 Sensors

Solid State /
 Reed Sensors

Weld Immune
 Sensors

Cordset/
 Connect Block

NAMUR
 Sensors

Proximity
 Sensors

PTR and HP Series Proximity Sensors

The inductive type proximity sensor provides end of rotation indication. The non-contact probe senses the presence of the ferrous cushion spear and has no springs, plungers, cams or dynamic seals that can wear out or go out of adjustment. The sensor is solid state and meets NEMA 3, 4, & 13 specifications. For ease of wiring, the connector housing is rotatable through 360°. To rotate, lift the cover latch, position, and release.

A standard proximity sensor controls 20-230 VAC/DC loads from 5 to 500 mA. The low 1.7 mA off-state leakage current can allow use for direct PLC input. The standard short circuit protection (SCP) protects the sensor from a short in the load or line upon sensing such a condition (5 amp or greater current) by assuming a non-conductive mode. The fault condition must be corrected and the power removed to reset the sensor preventing automatic restarts.

The low voltage DC sensor is also available for use with 10-30 VDC. This sensor is in a non-rotatable housing, but does incorporate the short circuit protection.

Both sensors are equipped with two LEDs, "Ready" and "Target". The "Ready" LED is lit when power is applied and the cushion spear is not present. The "Target" LED will light and the "Ready" LED will go out when the sensor is closed, indicating the presence of the cushion spear. Both LEDs flashing indicates a short circuit condition.

Notes:

1. Available with or without cushions.
2. Not available with stroke adjusters.
3. Pressure rating: 3000 PSIG
4. Operating temperature: -4°F to 150°F
5. Specify sensor type, orientation and voltage when ordering.
6. The low voltage DC sensor is available in non-rotatable style only, consult representative for further information.

B	Electronic Sensors
	Actuator Products
	Selection Guide
	Drop-in Sensors
	Solid State / Reed Sensors
	Weld Immune Sensors
	Cordset / Connect Block
	NAMUR Sensors
	Proximity Sensors

Inductive Proximity Sensors – 8mm Barrel Type

Proximity sensors are normally ordered with the unit as part of the model number. Use these part numbers for replacement parts only.

Ordering information

Series	PNP		NPN	
	Quick* connect	Flying leads	Quick ** connect	Flying leads
HB	B8830-P	913090000	B8830-N	913090100
P5L	B8830-P	913090000	B8830-N	913090100
WR	B8830-P	913090000	B8830-N	913090100

* Order cordset B8757-P separately.

** Order cordset B8757-N separately.

PNP wiring connection

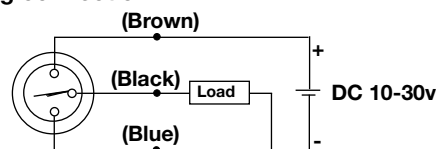

NPN wiring connection

